

Werkzeughalter | Toolholder

ISO 10

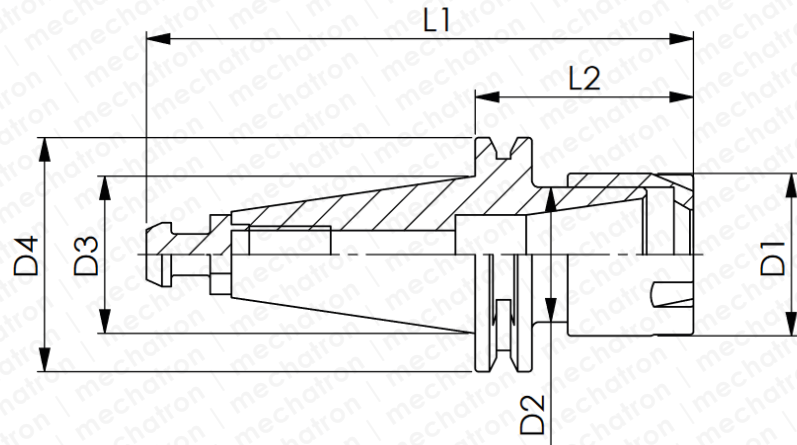

mechatron



| Ausführung Type | Maße* Dimensions* | | | | | | Spannbereich* Claming Range* |
|--------------------|---------------------|----|-------|----|------|------|---------------------------------|
| | D1 | D2 | D3 | D4 | L1 | L2 | |
| ER11 | 22 | 19 | 15,88 | 23 | 62,5 | 30,5 | 1-7 |
| ER16 | 16 | 16 | 15,88 | 16 | 16 | 16 | 1-7 |

*in mm

Anzugsbolzen inklusive